

15V TRIPLE IGBT/MOS DRIVER

- THREE POWER IGBT/MOS OR PULSE TRANSFORMER DRIVERS
- CURRENT SENSE COMPARATOR WITH 1ms INHIBITION TIME FUNCTION
- INSTANTANEOUS SIGNAL TRANSMISSION
- 0.6 Amp PER CHANNEL PEAK OUTPUT CURRENT CAPABILITY
- LOW OUTPUT IMPEDANCE TYP : 7Ω at 200mA
- CMOS/LSTTL COMPATIBLE INVERTING INPUT WITH HYSTERESIS
- 13V TO 16V SINGLE SUPPLY OPERATION
- UNDER VOLTAGE LOCKOUT (12.5V)
- CURRENT AMPLIFIER
- LOW BIAS CURRENT TYP : 1.5mA
- DURING POWER UP NO RANDOM OUTPUT STATE
- ENHANCED LATCH-UP IMMUNITY
- CHANNEL PARALLELING CAPABILITY

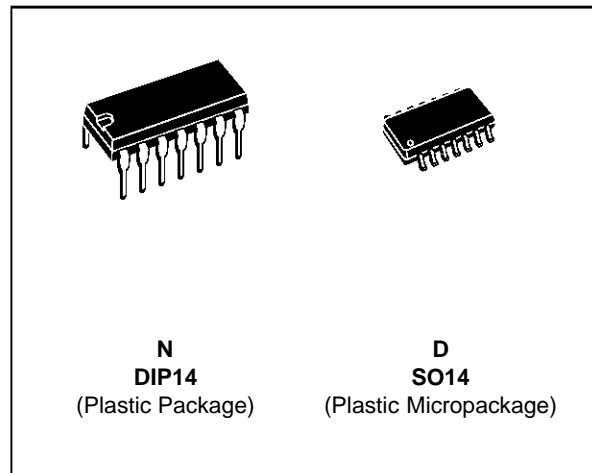

ORDER CODES

Part Number	Temperature Range	Package	
		N	D
TD300I	-40°C, +105°C	•	•

TD300-01.TBL

DESCRIPTION

The TD300 is designed to drive one, two or three Power IGBT/MOS and has driving capability for pulse transformer. So it is perfectly suited to interface control IC with Power Switches in low side or half-bridge configuration.

The typical application shown figure 1 implements the TD300 in a pulse controlled half-bridge drive. Positive and negative pulses are applied to the pulse transformer to charge and discharge the IGBT/MOS gate capacitance. More sophisticated secondary circuits provide low impedance gate drive and short-circuit protection as shown in application note AN461.

On Figure 2, TD300 is implemented as a low side driver in a typical 3 phase motor drive.

Figure 3 presents a general purpose low side gate drive.

In both case, the current amplifier provides interfacing between a sense resistor and an A/D converter.

PIN CONNECTIONS

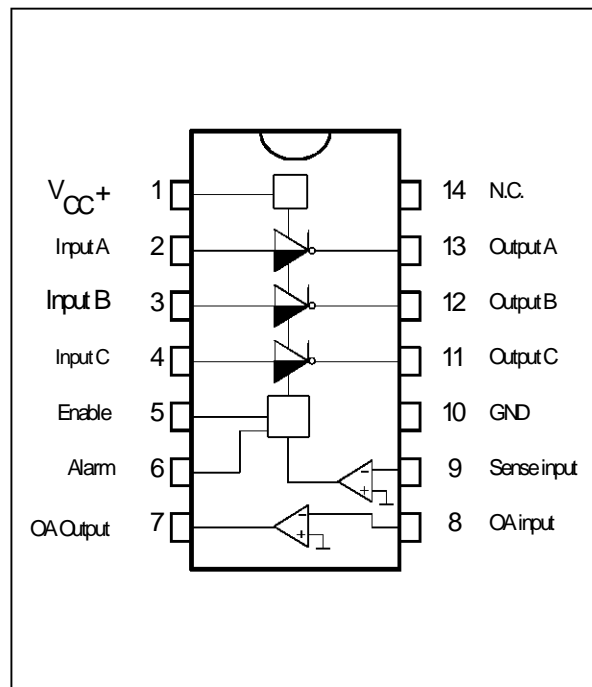

TD300-01.EPS

BLOCK DIAGRAM

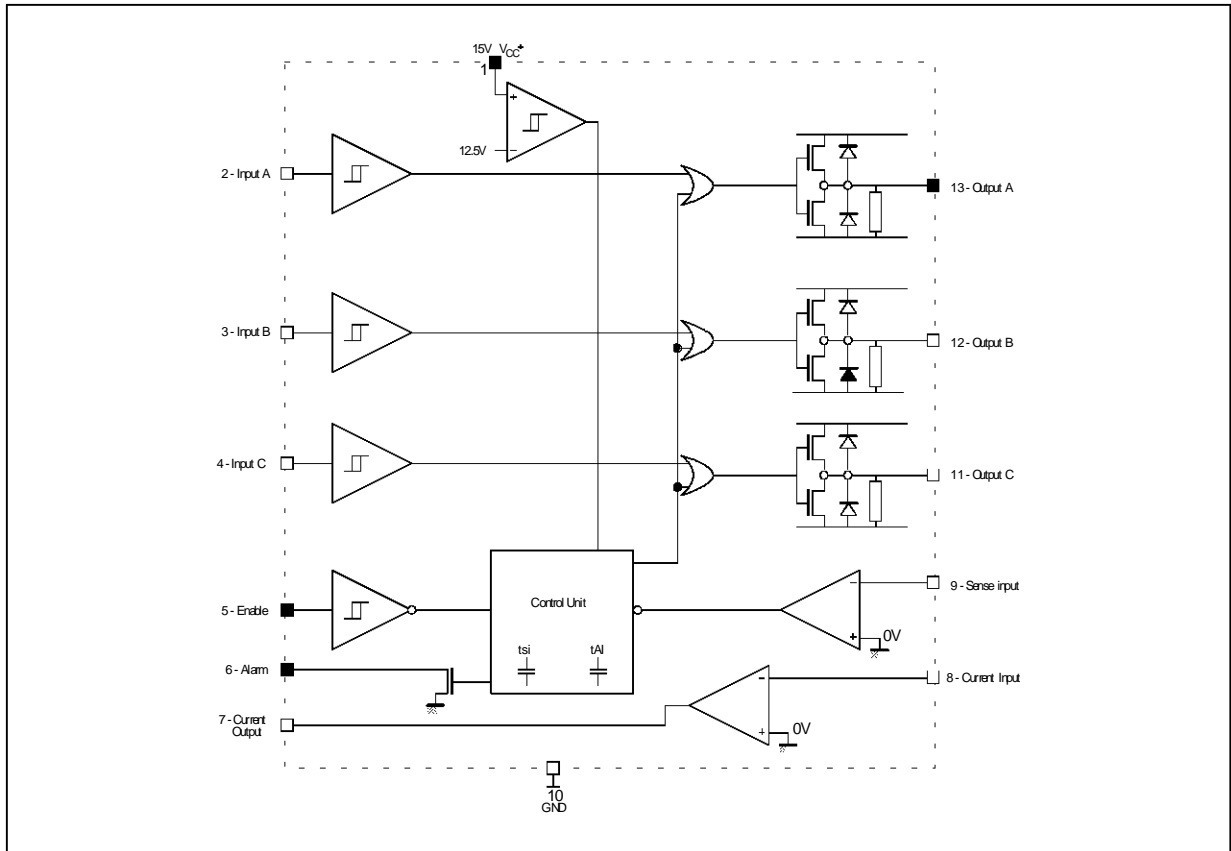

TD300-02.EPS

ABSOLUTE MAXIMUM RATINGS

Symbol	Parameter	Value	Unit
V _{CC}	Supply Voltage	18	V
V _i	Input Voltage	0 to V _{CC}	V
V _{is}	Sense Input Voltage	-0.3 to V _{CC}	V
T _j	Operating Junction Temperature	-40 to 150	°C
T _{amb}	Operating Ambient Temperature	-40 to 105	°C
T _{stg}	Storage Temperature Range	-65 to 150	°C

TD300-01.TBL

OPERATING CONDITIONS

Symbol	Parameter	Value	Unit
V _{CC}	Supply Voltage	13 to 16	V

TD300-03.TBL

INSTRUCTIONS FOR USE

- 1 - The TD300 supply voltage must be decoupled with a 1µF min. capacitor.
- 2 - If the application involving TD300 requires maximum output current capability,

ELECTRICAL CHARACTERISTICS

$V_{CC} = 15V$, $T_{amb} = 25^{\circ}C$ (unless otherwise specified)

Symbol	Parameter	Min.	Typ.	Max.	Unit
I_{CC}	Supply Current with Inputs in High State		1.5	2	mA
LOGIC INPUT (all inputs)					
V_{IH}	High Input Voltage	2			V
V_{IL}	Low Input Voltage			0.8	V
I_{IH}	High Input Current		10		pA
I_{IL}	Low Input Current		10		pA
t_{dH}, t_{eL} t_{dL}, t_{eH}	Propagation Delay (10% input to 10% output) Output Delay Output Delay $T_{min.} \leq T_{amb} \leq T_{max.}$		200 60	400 400	ns
t_{ij}	Input Inhibiting Time		100		ns
t_{dd}	Differential Delay Time Between Channels		20		ns
OUTPUT DRIVERS					
V_{sod}	Sourcing Drop Voltage (A/B/C outputs) $I_{source} = 200mA$			3	V
V_{sid}	Sinking Drop Voltage (A/B/C outputs) $I_{sink} = 200mA$			5	V
V_{dem}	Demagnetising Drop Voltage (A/B/C outputs) $I_{demag.} = 100mA$			2	V
R_{opd}	Output Pull Down Resistor		47		k Ω
UNDERVOLTAGE LOCKOUT					
V_{hys}	Threshold Hysteresis		0.8		V
V_{st}	Internal Start Threshold	11.7		13.3	V
ALARM OUTPUT					
I_s	Low Level Sinking Current $V_O = 0.8V$	5	35		mA
I_{sh}	High Level Sinking Current			500	nA
t_A	Alarm Output : Delay Time to Alarm Fall if Sense Input Triggered			500	ns
SENSE INPUT					
V_{ios}	Input Offset Voltage			20	mV
t_{Ai}	Inhibition Time if Sense Input Triggered		1		ms
t_s	Delay Time to Output Fall if Sense Input Triggered All outputs inhibited			600	ns
t_{si}	Inhibition Time of Sense Input		300		ns
V_{shys}	Sense Hysteresis		40		mV
OPERATIONAL AMPLIFIER					
V_{icm}	Common Mode Input Voltage Range	0 to $V_{CC}^+ - 1.5$			V
V_{io}	Input Offset Voltage			10	mV
I_{io}	Input Offset Current		1		pA
I_o	Output Short Circuit Current ($V_{id} = 100mV$, $V_o = 0V$)		60		mA
V_{OL}	Low Level Output Voltage ($V_{id} = -100mV$)		20		mV
V_{OH}	High Level Output Voltage ($V_{id} = 100mV$, $R_L = 100k\Omega$)		8.9		V
GBP	Gain Bandwidth Product		1		MHz
A_{vd}	Open Loop Gain	60			dB
SR	Slew Rate at Unity Gain ($R_L = 100k\Omega$, $C_L = 100pF$, $V_i = 3$ to $7V$)		0.6		V/ μs

TIMING DIAGRAM

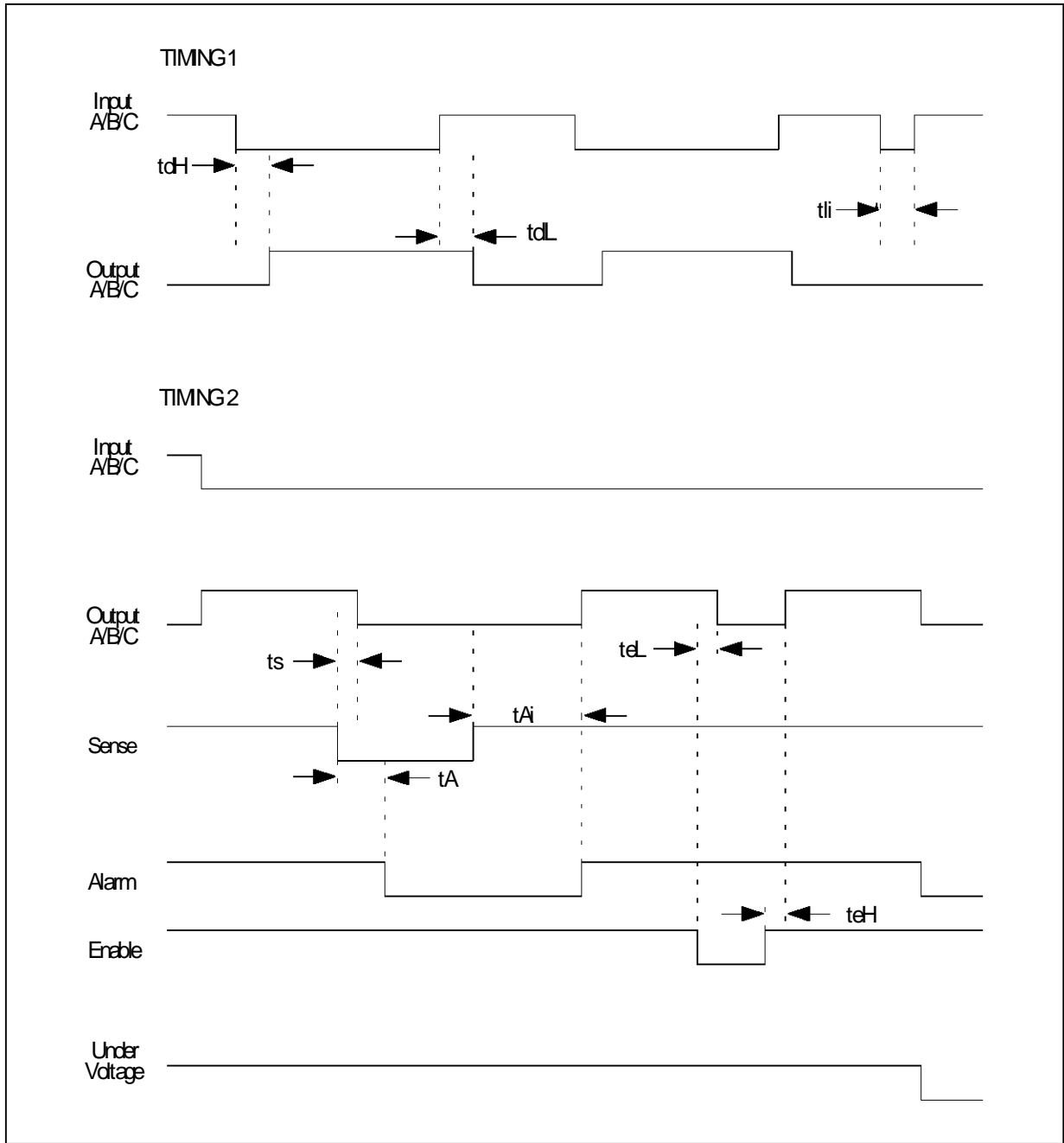

TD300-03.EPS

TYPICAL APPLICATIONS

Figure 1 : THREE PHASE MOTOR HIGH AND LOW SIDE DRIVE

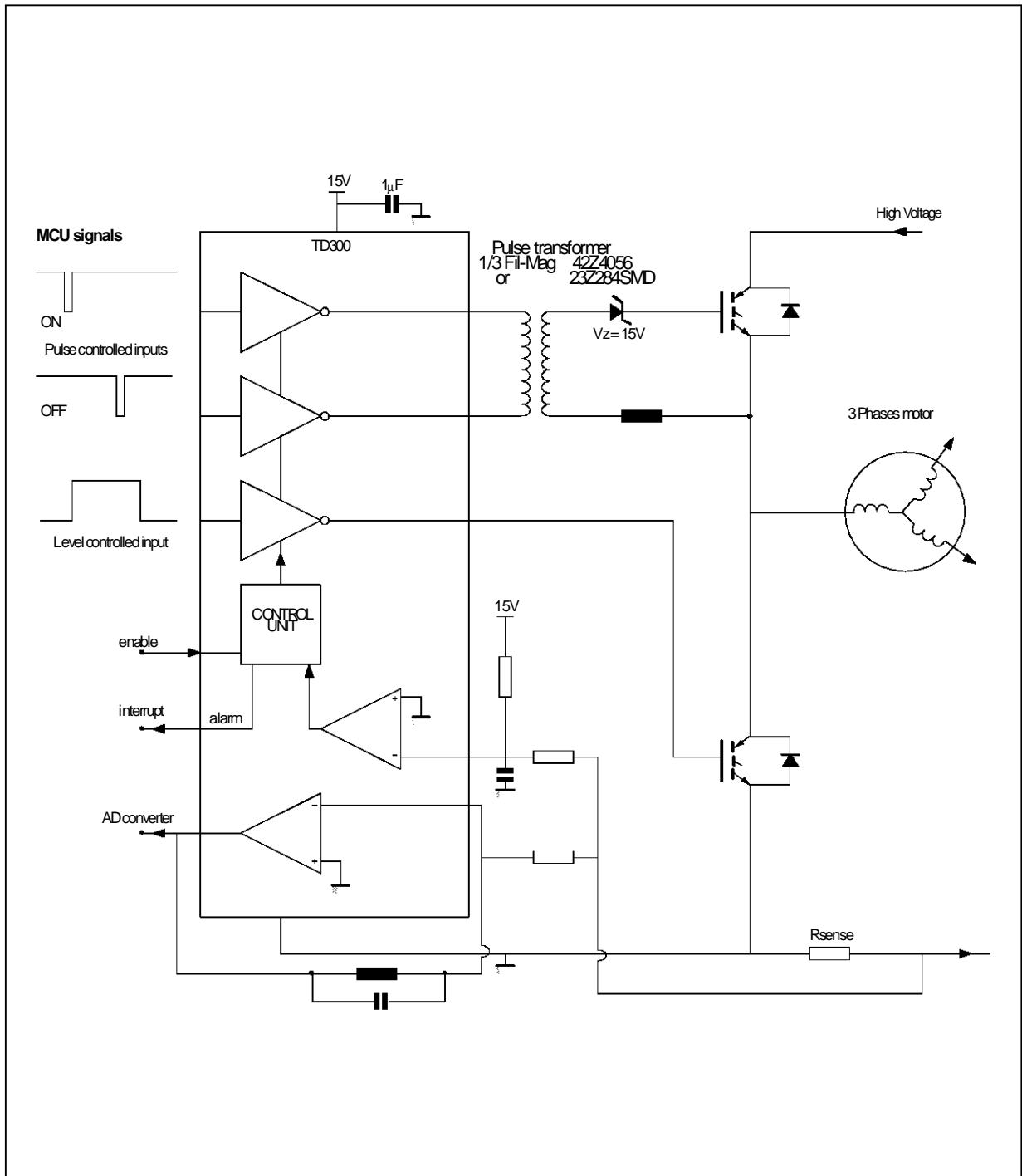

TD300-04.EPS

Figure 2 : THREE PHASE MOTOR LOW SIDE DRIVE

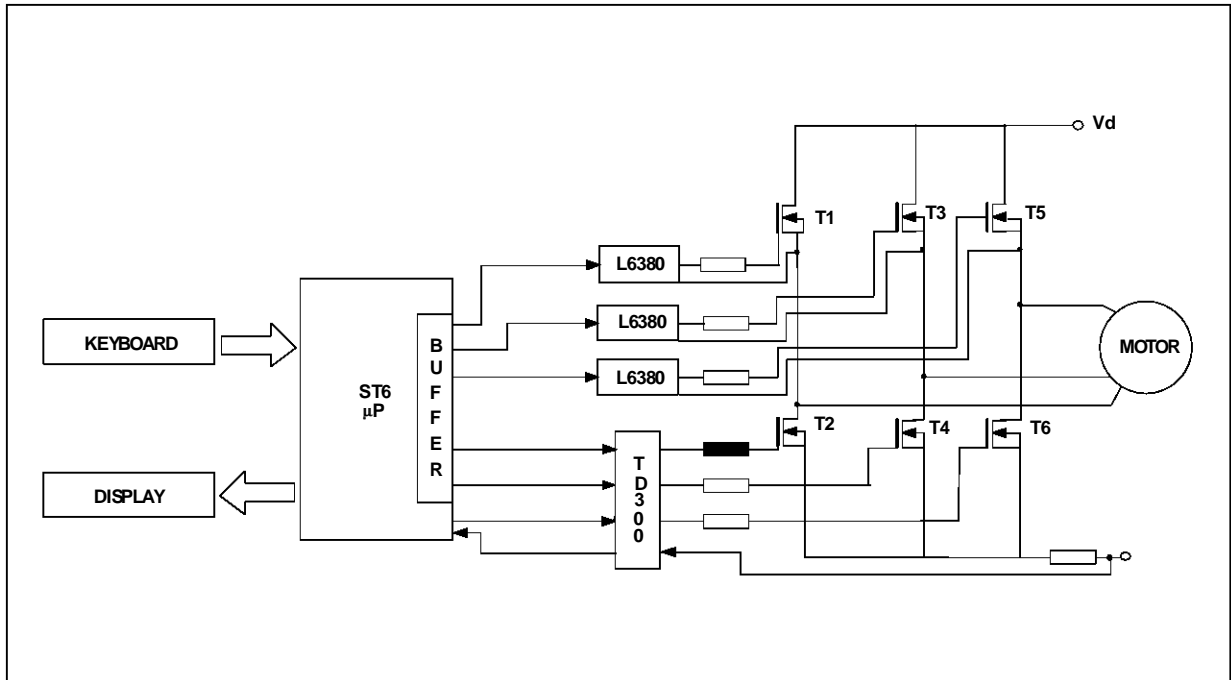

TD300-05.EPS

Figure 3 : LOW SIDE DRIVE

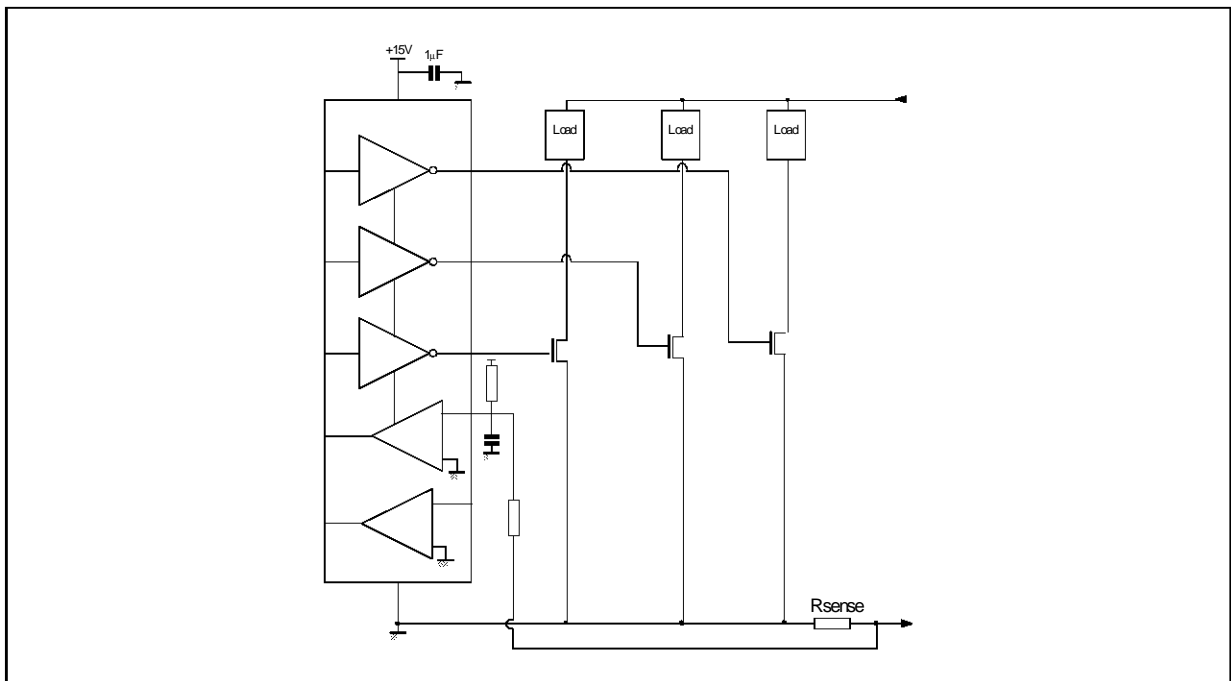

TD300-06.EPS

PACKAGE MECHANICAL DATA
14 PINS - PLASTIC DIP

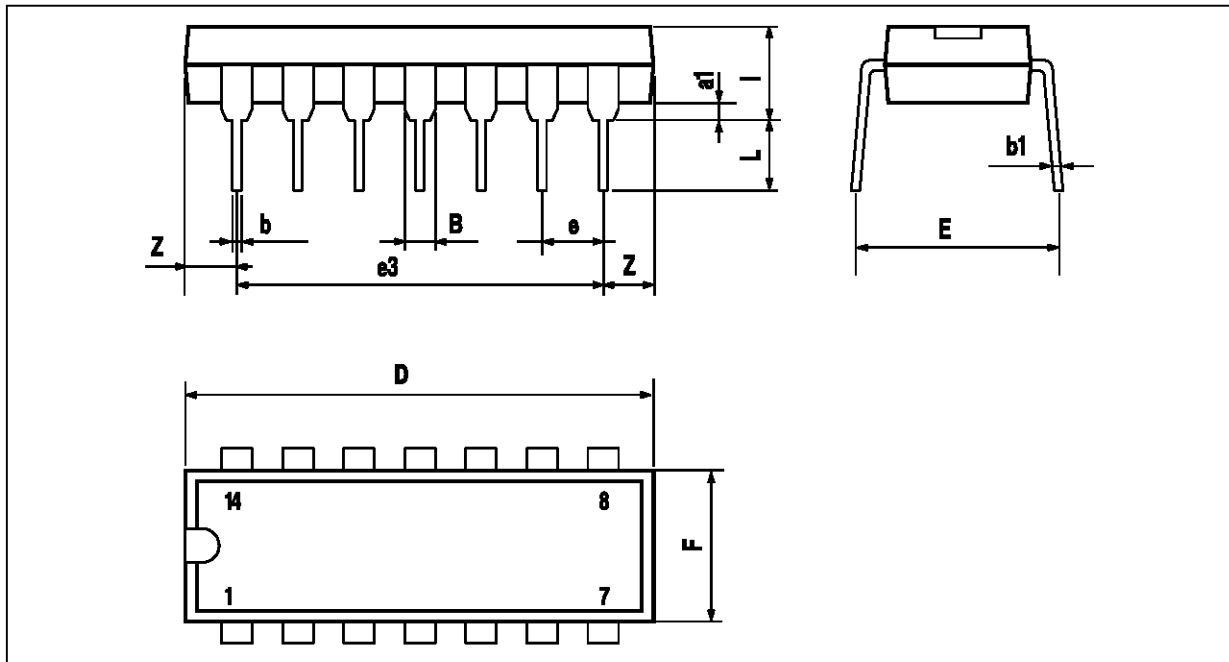

PM-DIP14.EPS

Dimensions	Millimeters			Inches		
	Min.	Typ.	Max.	Min.	Typ.	Max.
a1	0.51			0.020		
B	1.39		1.65	0.055		0.065
b		0.5			0.020	
b1		0.25			0.010	
D			20			0.787
E		8.5			0.335	
e		2.54			0.100	
e3		15.24			0.600	
F			7.1			0.280
i			5.1			0.201
L		3.3			0.130	
Z	1.27		2.54	0.050		0.100

DIP14.TBL

PACKAGE MECHANICAL DATA
 14 PINS - PLASTIC MICROPACKAGE (SO)

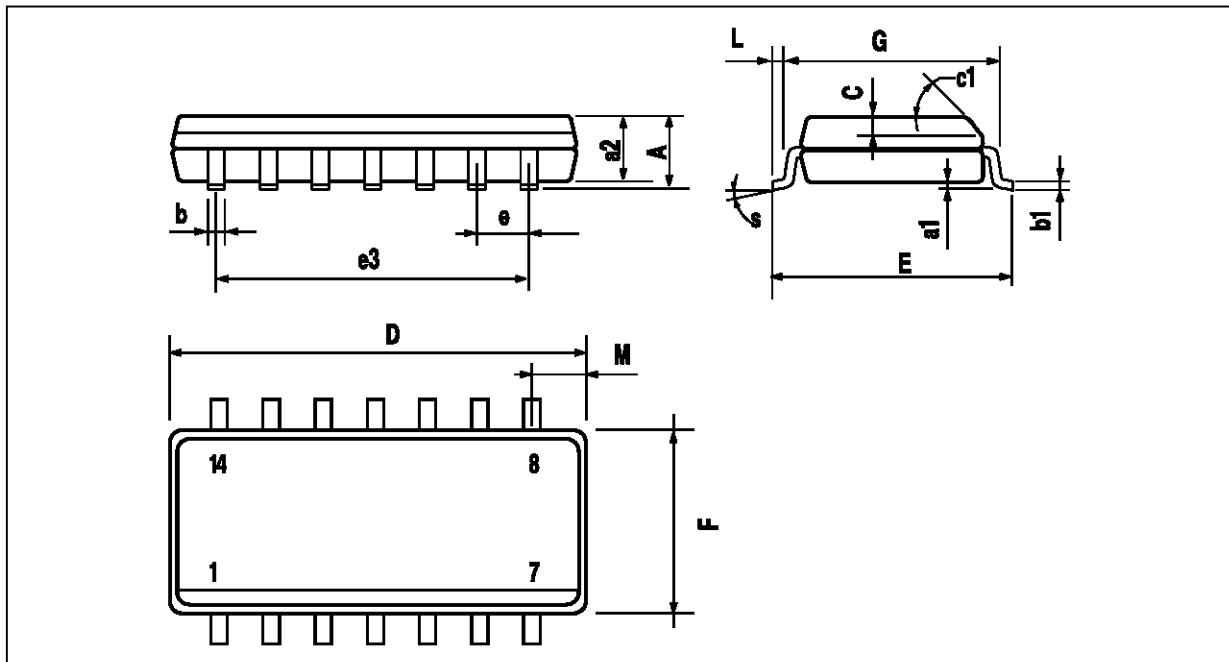

PM-S014.EPS

Dimensions	Millimeters			Inches		
	Min.	Typ.	Max.	Min.	Typ.	Max.
A			1.75			0.069
a1	0.1		0.2	0.004		0.008
a2			1.6			0.063
b	0.35		0.46	0.014		0.018
b1	0.19		0.25	0.007		0.010
C		0.5			0.020	
c1	45° (typ.)					
D	8.55		8.75	0.336		0.334
E	5.8		6.2	0.228		0.244
e		1.27			0.050	
e3		7.62			0.300	
F	3.8		4.0	0.150		0.157
G	4.6		5.3	0.181		0.208
L	0.5		1.27	0.020		0.050
M			0.68			0.027
S	8° (max.)					

SO14.TBL

Information furnished is believed to be accurate and reliable. However, SGS-THOMSON Microelectronics assumes no responsibility for the consequences of use of such information nor for any infringement of patents or other rights of third parties which may result from its use. No licence is granted by implication or otherwise under any patent or patent rights of SGS-THOMSON Microelectronics. Specifications mentioned in this publication are subject to change without notice. This publication supersedes and replaces all information previously supplied. SGS-THOMSON Microelectronics products are not authorized for use as critical components in life support devices or systems without express written approval of SGS-THOMSON Microelectronics.

© 1994 SGS-THOMSON Microelectronics - All Rights Reserved

SGS-THOMSON Microelectronics GROUP OF COMPANIES
 Australia - Brazil - France - Germany - Hong Kong - Italy - Japan - Korea - Malaysia - Malta - Morocco - The Netherlands
 Singapore - Spain - Sweden - Switzerland - Taiwan - Thailand - United Kingdom - U.S.A.

ORDER CODE :